

**GATE: 2008**  
**CE: CIVIL ENGINEERING**

1. The product of matrices  $(PQ)^{-1}P$  is  
(A)  $P^{-1}$  (C)  $P^{-1}Q^{-1}$   
(B)  $Q^{-1}$  (D)  $PQP^{-1}$
2. The general solution of  $\frac{d^2y}{dx^2} + y = 0$  is  
(A)  $y = P \cos x + Q \sin x$  (C)  $y = P \sin x$   
(B)  $y = P \cos x$  (D)  $y = P \sin^2 x$
3. A mild steel specimen is under uni-axial tensile stress. Young's modulus and yield stress for mild steel are  $2 \times 10^5$  MPa respectively. The maximum amount of strain energy per unit volume that can be stored in this specimen without permanent set is  
(A)  $156 \text{ Nmm/mm}^3$  (C)  $1.56 \text{ Nmm/mm}^3$   
(B)  $15.6 \text{ Nmm/mm}^3$  (D)  $0.156 \text{ Nmm/mm}^3$
4. A reinforced concrete structure has to be constructed along a sea coast. The minimum grade of concrete to be used as per IS: 456 – 2000 is  
(A) M 15 (C) M 25  
(B) M 20 (D) M 30
5. In the design of a reinforced concrete beam the requirement for bond is not getting satisfied. The economical option to satisfy the requirement for bond is by  
(A) Bundling of bars  
(B) Providing smaller diameter bars more in number  
(C) Providing larger diameter bars less in number  
(D) Providing same diameter bars more in number
6. The shape of the cross – section, which has a largest shape factor, is  
(A) Rectangular (C) Diamond  
(B) I – section (D) Solid circular
7. Group symbols assigned to silty sand and clayey sand are respectively  
(A) SS and CS (C) SM and SC  
(B) SM and CS (D) MS and CS
8. When a retaining wall moves away from the back – fill, the pressure exerted on the wall is termed as  
(A) Passive earth pressure (C) Pore pressure  
(B) Swelling pressure (D) Active earth pressure

9. Compaction by vibratory roller is the best method of compaction in case of  
(A) moist silty sand (C) clay of medium compressibility  
(B) well graded dry sand (D) silt of high compressibility
10. A person standing on the bank of a canal drops a stone on the water surface. He notices that the disturbance on the water is not traveling up-stream. This is because the flow in the canal is  
(A) Sub-critical (C) Steady  
(B) Super-critical (D) Uniform
11. A flood wave with a known inflow hydrograph is routed through a large reservoir. The outflow hydrograph will have  
(A) attenuated peak with reduced time-base (C) increased peak with increased time-base  
(B) attenuated peak with increased time-base (D) increased peak with reduced time-base
12. A stable channel is to be designed for a discharge of  $Q$  m<sup>3</sup>/s with silt factor  $f$  as per Lacey's method. The mean flow velocity (m/s) in the channel is obtained by  
(A)  $(Q f^2 / 140)^{1/6}$  (C)  $(Q^2 f^2 / 140)^{1/6}$   
(B)  $(Q f / 140)^{1/3}$  (D)  $0.48 (Q/f)^{1/3}$
13. The base width of an elementary profile of gravity dam of height  $H$  is  $b$ . The specific gravity of the material of the dam is  $G$  and uplift pressure coefficient is  $K$ . The correct relationship for no tension at the heel is given by  
(A)  $\frac{b}{H} = \frac{1}{\sqrt{G-K}}$  (C)  $\frac{b}{H} = \frac{1}{G-K}$   
(B)  $\frac{b}{H} = \sqrt{G-K}$  (D)  $\frac{b}{H} = \frac{1}{K\sqrt{G-K}}$
14. Two primary air pollutants are  
(A) Sulphur oxide and ozone  
(B) Nitrogen oxide and peroxyacetylnitrate  
(C) Sulphur oxide and hydrocarbon  
(D) Ozone and peroxyacetylnitrate
15. Two biodegradable components of municipal solid waste are  
(A) Plastics and wood (C) Leather and tin cans  
(B) Cardboard and glass (D) Food wastes and garden trimmings
16. The specific gravity of paving bitumen as per IS: 73 – 1992 lies between  
(A) 1.10 and 1.06 (C) 1.02 and 0.97  
(B) 1.06 and 1.02 (D) 0.97 and 0.92
17. A combined value of flakiness and elongation index is to be determined for a sample of aggregates. The sequence in which the two tests are conducted is

- (A) Elongation index test followed by flakiness index test on the whole sample.  
 (B) Flakiness index test followed by elongation index test on the whole sample.  
 (C) Flakiness index test followed by elongation index test on the non-flaky aggregates.  
 (D) Elongation index test followed by flakiness index test on non-elongated aggregates.
18. The capacities of “One-way 1.5m wide sidewalk (persons per hour)” and “One-way 2-lane urban road (PCU per hour, with no frontage access, no standing vehicles and very little cross traffic)” are respectively  
 (A) 1200 and 2400 (C) 1200 and 1500  
 (B) 1800 and 2000 (D) 2000 and 1200
19. The shape of the STOP sign according to IRC: 67-2001 is  
 (A) Circular (C) Octagonal  
 (B) Triangular (D) Rectangular
20. The type of surveying in which the curvature of the earth is taken into account is called  
 (A) Geodetic surveying (C) Preliminary surveying  
 (B) Plane surveying (D) Topographical surveying

**Q.21 to Q.75 carry two marks each**

21. The equation  $k_x \frac{\partial^2 h}{\partial x^2} + k_z \frac{\partial^2 h}{\partial z^2} = 0$  can be transformed to  $\frac{\partial^2 h}{\partial x_1^2} + \frac{\partial^2 h}{\partial z^2} = 0$  by substituting  
 (A)  $x_1 = x \frac{k_z}{k_x}$  (C)  $x_1 = x \sqrt{\frac{k_x}{k_z}}$   
 (B)  $x_1 = x \frac{k_x}{k_z}$  (D)  $x_1 = x \sqrt{\frac{k_z}{k_x}}$
22. The value of  $\int_0^3 \int_0^x (6 - x - y) dx dy$  is  
 (A) 13.5 (C) 40.5  
 (B) 27.0 (D) 54.0
23. Three values of x and y are to be fitted in a straight line in the form  $y = a + bx$  by the method of least squares. Given:  $\sum x = 6, \sum y = 21, \sum x^2 = 14$  and  $\sum xy = 46$ , the values of a and b are respectively  
 (A) 2 and 3 (C) 2 and 1  
 (B) 1 and 2 (D) 3 and 2
24. Solution of  $\frac{dy}{dx} = -\frac{x}{y}$  at  $x = 1$  and  $y = \sqrt{3}$  is  
 (A)  $x - y^2 = 2$  (C)  $x^2 - y^2 = -2$   
 (B)  $x + y^2 = 4$  (D)  $x^2 + y^2 = 4$
25. If probability density function of a random variable X is  $f(x) = x^2$  for  $-1 \leq x \leq 1$ , and

= 0 for any other value of  $x$

Then, the percentage probability  $P\left(-\frac{1}{3} \leq x \leq \frac{1}{3}\right)$  is

- (A) 0.247 (C) 24.7  
(B) 2.47 (D) 247
26. The Eigen values of the matrix  $[P] = \begin{bmatrix} 4 & 5 \\ 2 & -5 \end{bmatrix}$  are  
(A)  $-7$  and  $8$  (C)  $3$  and  $4$   
(B)  $-6$  and  $5$  (D)  $1$  and  $2$
27. A person on a trip has a choice between private car and public transport. The probability of using a private car is  $0.45$ . While using the public transport, further choices available are bus and metro, out of which the probability of commuting by a bus is  $0.55$ . In such a situation, the probability (rounded up to two decimals) of using a car, bus and metro, respectively would be  
(A)  $0.45, 0.30$  and  $0.25$  (C)  $0.45, 0.55$  and  $0.00$   
(B)  $0.45, 0.25$  and  $0.30$  (D)  $0.45, 0.35$  and  $0.20$
28. The following simultaneous equations  
 $x + y + z = 3$   
 $x + 2y + 3z = 4$   
 $x + 4y + kz = 6$   
will NOT have a unique solution for  $k$  equal to  
(A)  $0$  (C)  $6$   
(B)  $30$  (D)  $7$
29. The inner (dot) product of two vectors  $\vec{P}$  and  $\vec{Q}$  is zero. The angle (degrees) between the two vectors is  
(A)  $0$  (C)  $90$   
(B)  $5$  (D)  $120$
30. Cross-section of a column consisting of two steel strips, each of thickness  $t$  and width  $b$  is shown in the figure below. The critical loads of the column with perfect bond and without bond between the strips are  $P$  and  $P_0$  respectively. The ratio  $P/P_0$  is  
(A)  $2$  (C)  $6$   
(B)  $4$  (D)  $8$

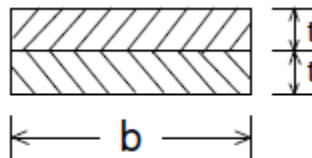

31. A rigid bar GH of length  $L$  is supported by a hinge and a spring of stiffness  $K$  as shown in the figure below. The buckling load,  $P_{cr}$ , for the bar will be

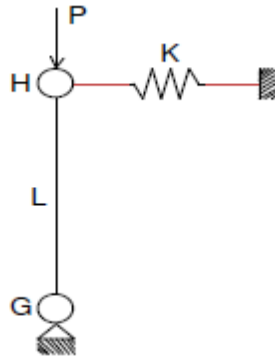

- (A)  $0.5 KL$  (B)  $0.8 KL$  (C)  $1.0 KL$  (D)  $1.2 KL$

32. The degree of static indeterminacy of the rigid frame having two internal hinges as shown in the figure below, is

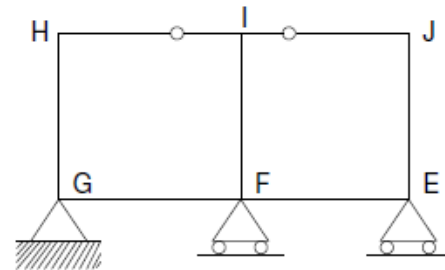

- (A) 8 (B) 7 (C) 6 (D) 5

33. The members EJ and IJ of a steel truss shown in the figure below are subjected to a temperature rise of  $30^\circ\text{C}$ . The coefficient of thermal expansion of steel is  $0.000012$  per  $^\circ\text{C}$  per unit length. The displacement (mm) of joint E relative to joint H along the direction HE of truss, is

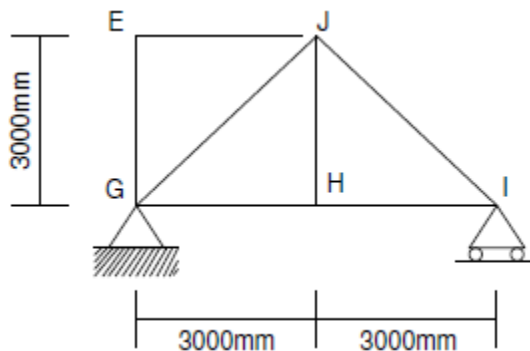

- (A) 0.255 (C) 0.764  
(B) 0.589 (D) 1.026

34. The maximum shear stress in a solid shaft of circular cross-section having diameter subjected to a torque  $T$  is  $\tau$ . If the torque is increased by four times and the diameter of the shaft is increased by two times, the maximum shear stress in the shaft will be  
(A)  $2\tau$  (C)  $\tau/2$   
(B)  $\tau$  (D)  $\tau/4$
35. The span(s) to be loaded uniformly for maximum positive (upward) reaction at support P, as shown in the figure below, is (are)

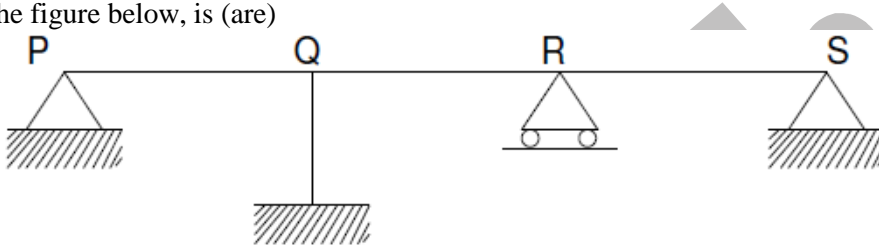

- (A) PQ only (C) QR and RS  
(B) PQ and QR (D) PQ and RS
36. A vertical PQ of length  $L$  is fixed at its top end P and has a flange to the bottom end Q. A weight  $W$  is dropped vertically from a height  $h$  ( $<L$ ) on to the flange. The axial stress in the rod can be reduced by  
(A) Increasing the length of the rod  
(B) Decreasing the length of the rod  
(C) Decreasing the area of cross-section of the rod  
(D) Increasing the modulus of elasticity of the material
37. Un-factored maximum bending moments at a section of a reinforced concrete beam resulting from a frame analysis are 50, 80, 120 and 180 kNm under dead, live, wind and earthquake loads respectively. The design moment (kNm) as per IS: 456- 2000 for the limit state of collapse (flexure) is  
(A) 195 (C) 345  
(B) 250 (D) 372
38. A reinforced concrete column contains longitudinal steel equal to 1 percent of net cross-sectional area of the column. Assume modular ration as 10. The loads carried (using the elastic theory) by the longitudinal steel and the net area of concrete, are  $P_s$  and  $P_c$  respectively. The ratio  $P_s/P_c$  expressed as percent is  
(A) 0.1 (C) 1.1  
(B) 1 (D) 10

39. A pre-tensioned concrete member of section  $200 \text{ mm} \times 250 \text{ mm}$  contains tendons of area  $500 \text{ mm}^2$  at the centre of gravity of the section. The pre-stress in tendons is  $1000 \text{ N/mm}^2$ . Assuming modular ratio as 10, the stress ( $\text{N/mm}^2$ ) in concrete is

- (A) 11 (C) 7  
(B) 9 (D) 5

40. Rivets and bolts subjected to both shear stress ( $\tau_{vf, cal}$ ) and axial tensile stress ( $\sigma_{tf, cal}$ ) shall be so proportioned that the stresses do not exceed the respective allowable stresses  $\tau_{vf}$  and  $\sigma_{tf}$  and the value of  $\left(\frac{\tau_{vf, cal}}{\tau_{vf}} + \frac{\sigma_{tf, cal}}{\sigma_{tf}}\right)$  does not exceed

- (A) 1.0 (C) 1.4  
(B) 1.2 (D) 1.8

41. A continuous beam is loaded as shown in the figure below. Assuming a plastic moment capacity equal to  $M_P$ , the minimum load at which the beam would collapse is

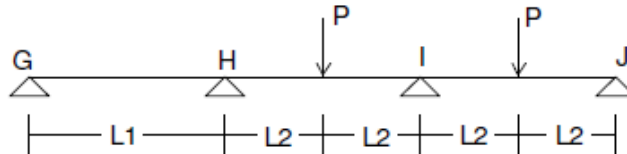

- (A)  $\frac{4M_P}{L}$  (C)  $\frac{8M_P}{L}$   
(B)  $\frac{6M_P}{L}$  (D)  $\frac{10M_P}{L}$

42. The maximum tensile stress at the section X-X shown in the figure below is

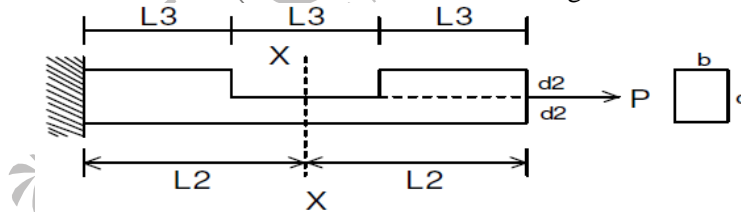

- (A)  $\frac{8P}{bd}$  (C)  $\frac{4P}{bd}$   
(B)  $\frac{6P}{bd}$  (D)  $\frac{2P}{bd}$

43. The stepped cantilever is subjected to movements,  $M$  as shown in the figure below. The vertical deflection at the free end (neglecting the self weight) is

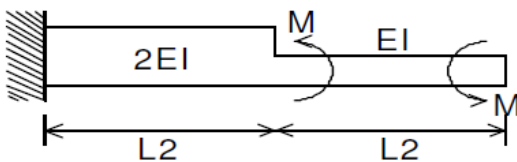

- (A)  $\frac{ML^2}{8EI}$  (C)  $\frac{ML^2}{2EI}$   
(B)  $\frac{ML^2}{4EI}$  (D) Zero
44. The liquid limit (LL), plastic limit (PL) and shrinkage limit (SL) of a cohesive soil satisfy the relation  
(A)  $LL > PL < SL$  (C)  $LL < PL < SL$   
(B)  $LL > PL > SL$  (D)  $LL < PL > SL$
45. A footing  $2\text{ m} \times 1\text{ m}$  exerts a uniform pressure of  $150\text{ kN/m}^2$  on the soil. Assuming a load dispersion of 2 vertical to 1 horizontal, the average vertical stress ( $\text{kN/m}^2$ ) at 1.0 m below the footing is  
(A) 50 (C) 80  
(B) 75 (D) 100
46. A direct shear test was conducted on a cohesion-less soil ( $c=0$ ) specimen under a normal stress of  $200\text{ kN/m}^2$ . The specimen failed at a shear stress of  $100\text{ kN/m}^2$ . The angle of internal friction of the soil (degrees) is  
(A) 26.6 (C) 30.0  
(B) 29.5 (D) 32.6
47. A pile of 0.50m diameter and length 10 m is embedded in a deposit of clay. The undrained strength parameters of the clay are cohesion =  $60\text{ kN/m}^2$  and the angle in internal friction = 0. The skin friction capacity (kN) of the pile for an adhesion factor of 0.6, is  
(A) 671 (C) 283  
(B) 565 (D) 106
48. A saturated clay stratum draining both at the top and bottom undergoes 50 percent consolidation in 16 years under an applied load. If an additional drainage layer were present at the middle of the clay stratum, 50 percent consolidation would occur in  
(A) 2 years (C) 8 years  
(B) 4 years (D) 16 years
49. A test plate  $30\text{ cm} \times 30\text{ cm}$  resting on a sand deposit settles by 10 mm under a certain loading intensity. A footing  $150\text{ cm} \times 200\text{ cm}$  resting on the same sand deposit and loaded to the same load intensity settles by  
(A) 2.0 mm (C) 3.02 mm  
(B) 27.8 mm (D) 50.0 mm
50. A volume of  $3.0 \times 10^6\text{ m}^3$  of groundwater was pumped out from an unconfined aquifer, uniformly from an area of  $5\text{ km}^2$ . The pumping lowered the water table from initial level of 102 m to 99 m. The specific yield of the aquifer is  
(A) 0.20 (C) 0.40  
(B) 0.30 (D) 0.50

51. A weir on a permeable foundation with down-stream sheet pile is shown in the figure below. The exit gradient as per Khosla's method is

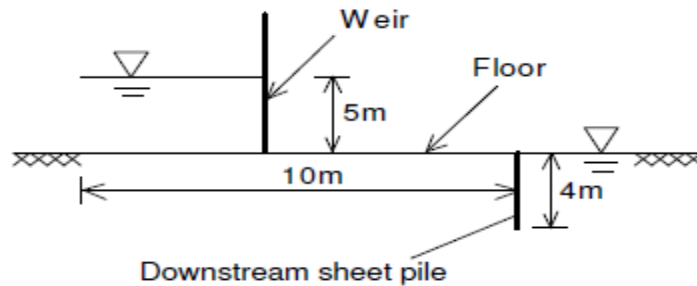

52. Water emerges from an ogee spillway with velocity = 13.72 m/s and depth = 0.3 m at its toe. The tail water depth required to form a hydraulic jump at the toe is  
 (A) 6.48 m (C) 3.24 m  
 (B) 5.24 m (D) 2.24 m
53. The flow of water (mass density = 1000 kg/m<sup>3</sup> and kinematic viscosity = 10<sup>-6</sup>m<sup>2</sup>/s) in a commercial pipe, having equivalent roughness  $k_s$  as 0.12 mm, yields an average shear stress at the pipe boundary = 600 N/m<sup>2</sup>. The value of  $k_s / \delta'$  ( $\delta'$  being the thickness of laminar sub-layer) for this pipe is  
 (A) 0.25 (C) 6.0  
 (B) 0.50 (D) 8.0
54. A river reach of 2.0 km long with maximum flood discharge of 10000 m<sup>3</sup>/s is to be physically modeled in the laboratory where maximum available discharge is 0.20m<sup>3</sup>/s. For a geometrically similar model based on equality of Froude number, the length of the river reach (m) in the model is  
 (A) 26.4 (C) 20.5  
 (B) 25.0 (D) 18.0
55. An outlet irrigates an area of 20 ha. The discharge (l/s) required at this outlet to meet the evapotranspiration requirement of 20 mm occurring uniformly in 20 days neglecting other field losses is  
 (A) 2.52 (C) 2.01  
 (B) 2.31 (D) 1.52
56. A wastewater sample contains 10<sup>-56</sup> mmol /l of OH<sup>-</sup> ions at 25°C. The pH of this sample is  
 (A) 8.6 (C) 5.6  
 (B) 8.4 (D) 5.4
57. Group I lists estimation methods of some of the water and wastewater quality parameters. Group II lists the indicators used in the estimation methods. Match the estimation method (Group I) with the corresponding indicator (Group II).

## Group I

- P. Azide modified Winkler method for dissolved oxygen  
 Q. Dichromate method for chemical oxygen demand  
 R. EDTA titrimetric method for hardness  
 S. Mohr or Argentometric method for chlorides

## Group II

1. Eriochrome Black T  
 2. Ferrion  
 3. Potassium chromate  
 4. Starch

- (A) P – 3, Q – 2, R – 1, S – 4  
 (B) P – 4, Q – 2, R – 1, S – 3

- (C) P – 4, Q – 1, R – 2, S – 3  
 (D) P – 4, Q – 2, R – 3, S – 1

58. Determine the correctness or otherwise of the following Assertion [a] and Reason [r]  
**Assertion:** The crown of the outgoing larger diameter sewer is always matched with the crown of incoming smaller diameter sewer.

**Reason:** It eliminates backing up of sewage in the incoming smaller diameter sewer.

- (A) Both [a] and [r] are true and [r] is the correct reason for [a].  
 (B) Both [a] and [r] are true but [r] is not the correct reason for [a].  
 (C) Both [a] and [r] are false  
 (D) [a] is true but [r] is false

59. The 5-day BOD of a wastewater sample is obtained as 190 mg/l (with  $k = 0.01 \text{ h}^{-1}$ ). The ultimate oxygen demand (mg/l) of the sample will be

- (A) 3800  
 (B) 475  
 (C) 271  
 (D) 190

60. A water treatment plant is required to process  $28800 \text{ m}^3/\text{d}$  of raw water (density =  $1000 \text{ kg/m}^3$ , kinematic viscosity =  $10^{-6} \text{ m}^2/\text{s}$ ). The rapid mixing tank imparts a velocity gradient of  $900 \text{ s}^{-1}$  to blend 35 mg/l of alum with the flow for a detention time of 2 minutes. The power input (W) required for rapid mixing is

- (A) 32.4  
 (B) 36  
 (C) 324  
 (D) 32400

61. Match Group I (Terminology) with Group II (Definition / Brief Description) for wastewater treatment systems

## Group I

- P. Primary treatment  
 Q. Secondary treatment  
 R. Unit operation  
 S. Unit process

## Group II

1. Contaminant removal by physical forces  
 2. Involving biological and / or chemical reaction  
 3. Conversion of soluble organic matter to biomass  
 4. Removal of solid materials from incoming wastewater

- (A) P – 4, Q – 3, R – 1, S – 2  
 (B) P – 4, Q – 3, R – 2, S – 1

- (C) P – 3, Q – 4, R – 2, S – 1  
 (D) P – 1, Q – 2, R – 3, S – 4

62. A roundabout is provided with an average entry width of 8.4 m, width of weaving section as 14 m, and length of the weaving section between channelizing islands as 35 m. The crossing traffic

and total traffic on the weaving section are 1000 and 2000 PCU per hour respectively. The nearest rounded capacity of the roundabout (in PCU per hour) is

- (A) 3300 (C) 4500  
(B) 3700 (D) 5200

63. Design parameters for a signalized intersection are shown in the figure below. The green time calculated for major and minor roads are 34 and 18 s, respectively.

The critical lane volume on the major road changes to 440 vehicles per hour per lane and the critical lane volume on the minor road remains unchanged. The green time will

- (A) Increase for the major road and remain same for the minor road.  
(B) Increase for the major road and decrease for the minor road.  
(C) Decrease for both the roads.  
(D) Remain unchanged for both the roads.

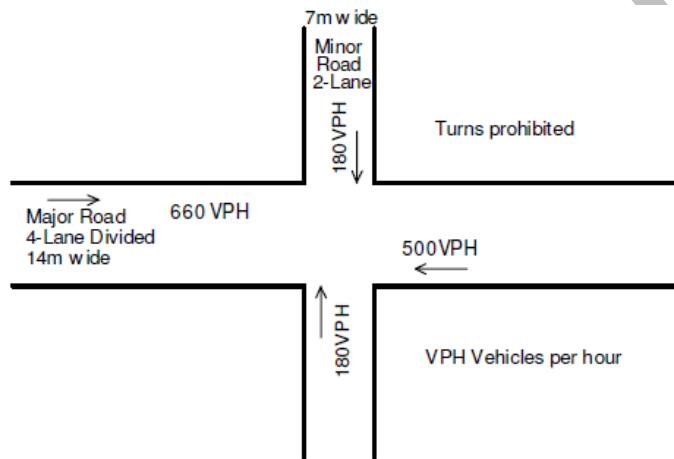

64. It is proposed to widen and strengthen an existing 2-lane NH section as a divided highway. The existing traffic in one direction is 2500 commercial vehicles (CV) per day. The construction will take 1 year. The design CBR of soil subgrade is found to be 5 percent. Given: traffic growth rate for CV = 8 percent, vehicle damage factor = 3.5 (standard axles per CV), design life = 10 years and traffic distribution factor = 0.75. The cumulative standard axles (msa) computed are

- (A) 35 (C) 65  
(B) 37 (D) 70

65. A linear relationship is observed between speed and density on a certain section of a highway. The free flow speed is observed to be 80 km per hour and the jam density is estimated as 100 vehicles per km length. Based on the above relationship, the maximum flow expected on this section and the speed at the maximum flow will respectively be

- (A) 8000 vehicles per hour and 80 km per hour (C) 2000 vehicles per hour 80 km per hour.  
(B) 8000 vehicles per hour and 25 km per hour (D) 2000 vehicles per hour 40 km per hour

66. The plan of a survey plotted to a scale of 10 m to 1 cm is reduced in such a way that a line originally 10 cm long now measures 9 cm. The area of the reduced plan is measured as 81 cm<sup>2</sup>. The actual (m<sup>2</sup>) of the survey is
- (A) 10000 (C) 1000  
(B) 6561 (D) 656

67. The length and bearings of a closed traverse PQRSP are given below.

Line	Length (m)	Bearing (WCB)
PQ	200	0°
QR	1000	45°
RS	907	180°
SP	?	?

The missing length and bearing, respectively of the line SP are

- (A) 207 m and 270° (C) 707 m and 180°  
(B) 707 m and 270° (D) 907 m and 270°
68. The focal length of the object glass of a tacheometer is 200 mm, the distance between the vertical axis of the tacheometer and the optical center of the object glass is 100 mm and the spacing between the upper and lower line of the diaphragm axis is 4 mm. with the line of collimation perfectly horizontal, the staff intercepts are 1 m (top), 2 m (middle), and 3 m (bottom). The horizontal distance (m) between the staff and the instrument station is
- (A) 100.3 (C) 150.0  
(B) 103.0 (D) 153.0
69. A road is provided with a horizontal circular curve having deflection angle 55° and centre line radius of 250 m. A transition curve is to be provided at each end of the circular curve of such a length that the rate of gain of radial acceleration is 0.3 m/s<sup>3</sup> at curve required at each of the ends is
- (A) 2.57 m (C) 35.73 m  
(B) 33.33 m (D) 1666.67 m

70. A light house of 120 m height is just visible above the horizon from a ship. The correct distance (m) between the ship and the light house considering combined correction for curvature and refraction, is
- (A) 39.098 (C) 39098  
(B) 42.226 (D) 42226

#### Common Data Questions 71, 72, 73:

A rectangular channel 6.0 m wide carries a discharge of 16.0 m<sup>3</sup>/s under uniform condition with normal depth of 1.60 m. Manning's n is 0.015.

71. The longitudinal slope of the channel is
- (A) 0.000585 (B) 0.000485

(C) 0.000385

(D) 0.000285

72. A hump is to be provided on the channel bed. The maximum height of the hump without affecting the upstream flow condition is  
 (A) 0.50 m (C) 4.1 m  
 (B) 3.8 m (D) 4.5 m
73. The channel width is to be contracted. The minimum width to which the channel can be contracted without affecting the upstream flow condition is  
 (A) 3.0 m (C) 4.1 m  
 (B) 3.8 m (D) 4.5 m

**Common Data for Questions 74 and 75:**

A reinforced concrete beam of rectangular cross section of breadth 230 mm and effective depth 400 mm is subjected to maximum factored shear force of 120 kN. The grades of concrete, main steel and stirrup steel are M20, Fe415 and Fe250 respectively. For the area of main steel provided, the design shear strength  $\tau_c$  is per IS: 456-2000 is  $0.48\text{N/mm}^2$ . The beam is designed for collapse limit state.

74. The spacing (mm) of 2-legged 8 mm stirrups to be provided is  
 (A) 40 (C) 250  
 (B) 115 (D) 400
75. In addition, the beam is subjected to a torque whose factored value is 10.90 kNm. The stirrups have to be provided to carry a shear (kN) equal to  
 (A) 50.42 (C) 151.67  
 (B) 130.56 (D) 200.23

**Linked Answer Questions: Q.76 to Q.85 carry two marks each**  
**Statement for Linked Answer Questions 76 and 77:**

Beam GHI is supported by these pontoons as shown in the figure below. The horizontal cross-sectional area of each pontoon is  $8\text{ m}^2$ , the flexural rigidity of the beam is  $10000\text{ kN-m}^2$  and the unit weight of water is  $10\text{ kN-m}^3$ .

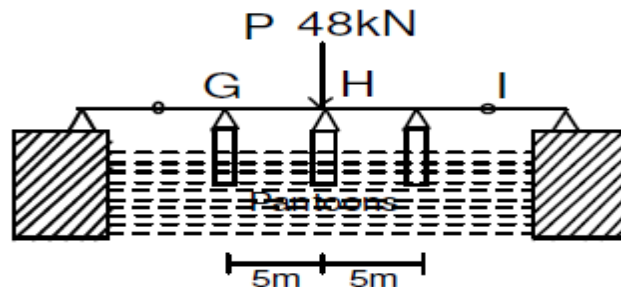

76. When the middle pontoon is removed, the deflection at H will be

- (A) 0.2 m (C) 0.6 m  
 (B) 0.4 m (D) 0.8 m

77. When the middle pontoon is brought back to its position as shown in the figure above, the reaction at H will be  
 (A) 8.6 kN (C) 19.2 kN  
 (B) 15.7 kN (D) 24.2 kN

**Statement for Linked Answer Questions 78 and 79:**

The ground conditions at site are shown in the figure below

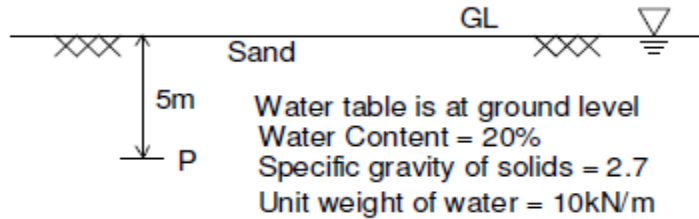

78. The saturated unit weight of the sand ( $\text{kN/m}^3$ ) is  
 (A) 15 (C) 21  
 (B) 18 (D) 24
79. The total stress, pore water pressure and effective stress ( $\text{kN/m}^2$ ) at the point P are, respectively  
 (A) 75, 50 and 25 (C) 105, 50 and 55  
 (B) 90, 50 and 40 (D) 120, 50 and 70

**Statement for Linked Answer Questions 80 and 81:**

A column is supported on a footing as shown in the figure below. The water table is at a depth of 10 m below the base of the footing.

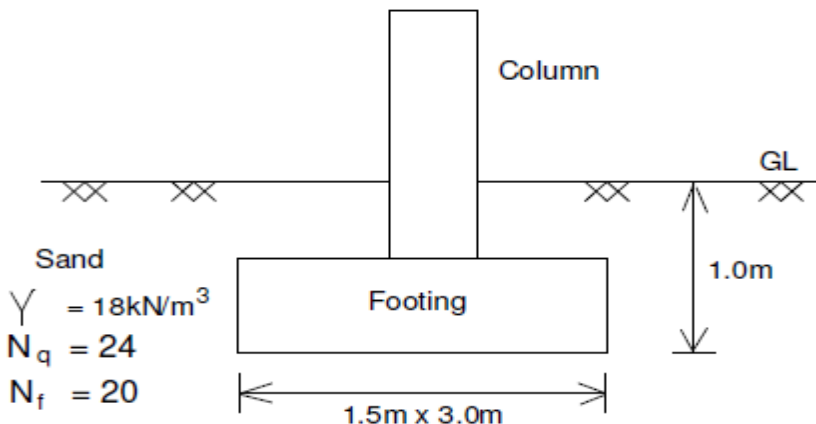

80. The net ultimate bearing capacity ( $\text{kN/m}^2$ ) of the footing based on Terzaghi's bearing capacity equation is
- (A) 216 (C) 630  
(B) 432 (D) 846
81. The safe load (kN) that the footing can carry with a factor of safety 3 is
- (A) 282 (C) 945  
(B) 648 (D) 1269

**Statement for Linked Answer Questions 82 and 83:**

An automobile with projected area  $2.6 \text{ m}^2$  is running on a road with speed of 120 km per hour. The mass density and the kinematic viscosity of air are  $1.2 \text{ kg/m}^3$  and  $1.5 \times 10^{-5} \text{ m}^2/\text{s}$ , respectively. The drag coefficient is 0.30.

82. The drag force on the automobile is
- (A) 620 N (C) 580 N  
(B) 600 N (D) 520 N
83. The metric horse power required to overcome the drag force is
- (A) 33.23 (C) 23.23  
(B) 31.23 (D) 20.23

**Statement for Linked Answer Questions 84 and 85**

A horizontal circular curve with a centre line radius of 200 m is provided on a 2-lane, 2-way SH section. The width of the 2-lane road is 7.0 m. Design speed for this section is 80 km per hour. The brake reaction time is 2.4 s, and the coefficients of friction in longitudinal and lateral directions are 0.355 and 0.15, respectively.

84. The safe stopping sight distance on the section is
- (A) 221 m (C) 125 m  
(B) 195 m (D) 65 m
85. The set-back distance from the centre line of the inner lane is
- (A) 7.93 m (C) 9.60 m  
(B) 8.10 m (D) 9.77 m